

---

## Middle Primary Division Round 2

---

### Questions 1 to 5, 4 marks each

1. What is the sum of the digits of the value of  $100 \times 100 - 2015$  ?  
(A) 27            (B) 29            (C) 30            (D) 34            (E) 39

Answer: \_\_\_\_\_

2. If  $6 \otimes 2 = 6 + 66 = 72$  and  $2 \otimes 3 = 2 + 22 + 222 = 246$ , what is the value of  $5 \otimes 3$  ?  
(A) 3735            (B) 605            (C) 615            (D) 625            (E) 37035

Answer: \_\_\_\_\_

3. In a gymnastic competition, an athlete receives a score from each of seven judges. After the highest score and the lowest score have been removed, the average of the remaining five scores is the actual score for that athlete. If the seven judges give scores of 9.2, 9.5, 9.3, 9.6, 9.1, 9.6 and 9.4 to an athlete, what is the actual score for this athlete?



- (A) 9.3            (B) 9.38            (C) 9.4            (D) 9.42            (E) 9.5

Answer: \_\_\_\_\_

4. In a shopping mall, a ball is drawn from one of the five boxes shown below. A door prize is won if the number of the ball is 1. From which box should a ball be drawn so that the chance of winning a door prize is as large as possible?

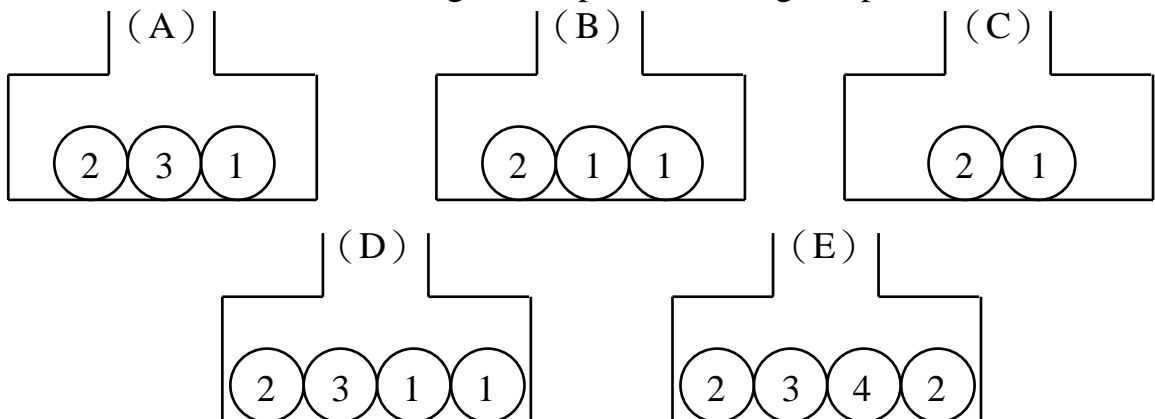

Answer: \_\_\_\_\_

---

5. Which of the following five figures is not possible to trace without lifting the pencil from the paper or retracing any part of it?

(A)

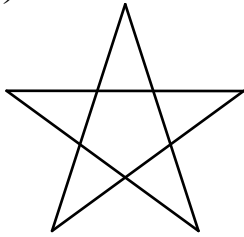

(B)

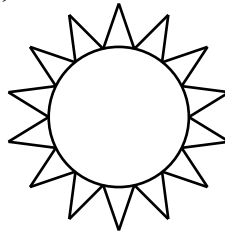

(C)

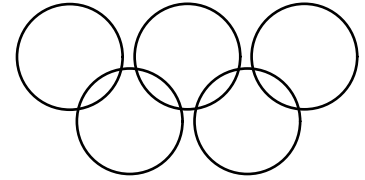

(D)

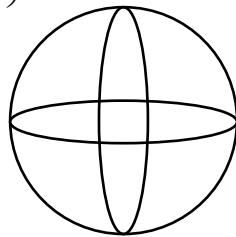

(E)

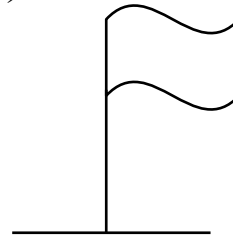

Answer: \_\_\_\_\_

---

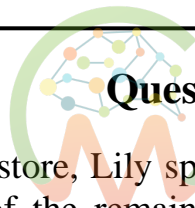
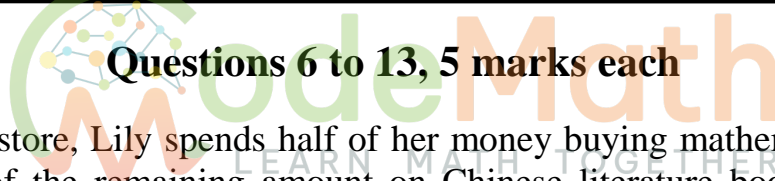
 **Questions 6 to 13, 5 marks each** 

6. At the bookstore, Lily spends half of her money buying mathematics books and two-thirds of the remaining amount on Chinese literature books. She has just enough money left to buy an English literature book which costs \$18. How much money does Lily have initially?

Answer: \$ \_\_\_\_\_

7. There are three kinds of objects, spheres, cylinders and cubes. Three spheres have the same total weight as two cylinders, and five spheres have the same total weight as six cubes. How many cubes will have the same total weight as five cylinders?

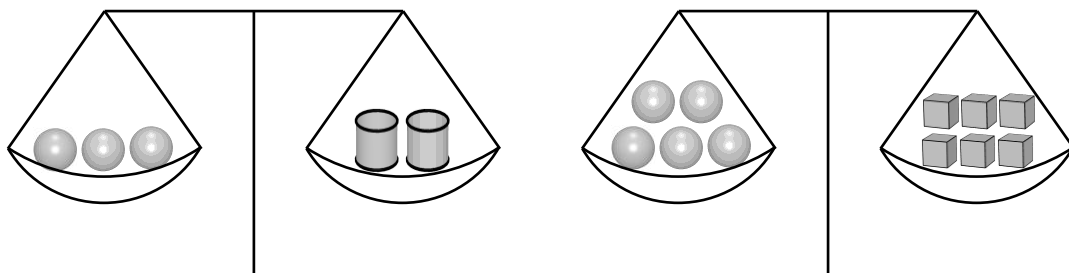

Answer: \_\_\_\_\_ cubes

---

---

**MP 3**

---

8. In a video game, 1 point is awarded for eating the first apple, 2 points for eating the second apple, and so on, with 1 additional point awarded for the next apple eaten. What is the total number of points awarded for eating ten apples?



Answer: \_\_\_\_\_ points

---

9. In the month of May of a certain year, there are five Sundays and four Mondays. On which day of the week does May 1 fall in that year?

(Using 0 to represent Sunday, 1 to represent Monday, 2 to represent Tuesday, 3 to represent Wednesday, 4 to represent Thursday, 5 to represent Friday, 6 to represent Saturday.)



Answer: \_\_\_\_\_

---

10. In the following diagram, how many different triangles are there, including overlapping triangles?

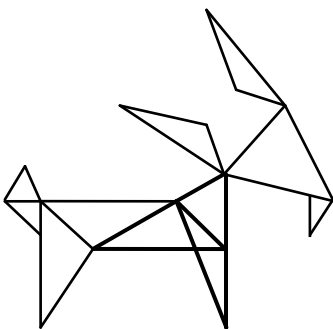

Answer: \_\_\_\_\_ triangles

---

11. There are 20 children at a party. The first girl shakes hands with 7 boys. The second girl shakes hands with 8 boys. The third girl shakes hands with 9 boys, and so on. The last girl shakes hands with all the boys. How many boys are at the party?

Answer: \_\_\_\_\_

12. The school has six enrichment clubs. Mickey wants to join three of them. However, there are two clubs running at the same time, he only can at most choose one of them. How many different choices does he have?



Answer: \_\_\_\_\_ choices

13. A square garden has a square pavilion at its centre. The distance on each outer side of the pavilion to its corresponding side of the garden is 8 m. If the total area of the part of the garden outside the pavilion is  $448 \text{ m}^2$ , what is the area, in  $\text{m}^2$ , of the pavilion?

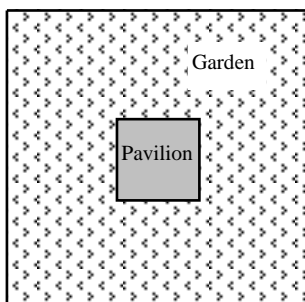

Answer: \_\_\_\_\_  $\text{m}^2$

---

**Questions 14 to 15, 20 marks each**

**(Detailed solutions are needed for these two problems)**

14. One digit is chosen from each of the three groups  $\{1, 4, 7\}$ ,  $\{2, 5, 8\}$  and  $\{3, 6, 9\}$ . The chosen digits are arranged in any order to form a three-digit number. How many such three-digit numbers are divisible by 6?



Answer: \_\_\_\_\_ numbers

---

15. Each side of an equilateral triangle is divided into 4 equal parts by 3 points, and these points are joined by lines parallel to the sides of the triangle, dividing into 16 small equilateral triangles. A tetriamond is a shape formed of 4 small equilateral triangles joined edge to edge.

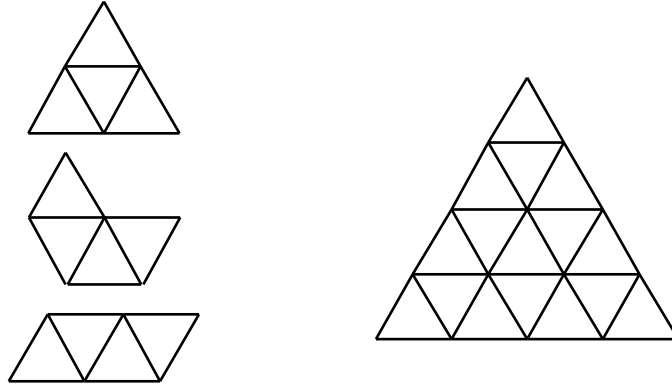

- (a) Show that if 4 of the small triangles are painted, then it may be impossible to fit any tetriamond inside the large triangle without covering up any part of the painted small triangles. (4 marks)



- (b) Prove that if 3 of the small triangles are painted, then it is always possible to fit any tetriamond inside the large triangle without covering up any part of the painted small triangles. (16 marks)

